

## SPECIALTY PUMPS

Jacques Chaurette p. eng.  
www.lightmypump.com  
October 2004

### Synopsis

My intention in this article is too highlight some specialty pumps with characteristics that are unusual and helpful in particular situations. Some of these pumps are mentioned in the Hydraulic Institute classification of centrifugal pumps by mechanical type which you can view at [http://www.lightmypump.com/pumpdatabase/hydraulic\\_institute-chart.htm](http://www.lightmypump.com/pumpdatabase/hydraulic_institute-chart.htm).

### 1.0 JET PUMPS

This pump is used frequently for domestic water supply. It is a typical centrifugal pump with the difference that the suction is augmented by a venturi which creates a vacuum allowing water to be lifted from a deep well. It is an ingenious use of the pump own discharge pressure and flow to provide pressure water at the inlet of a venturi which is located in the pump suction. The jet of water is accelerated in the small diameter of the venturi which creates a low pressure or vacuum, this vacuum is used to assist in lifting the water in the well to the suction compartment of the pump (see Figure 1b). One big advantage is there is no need to use a foot valve (i.e. check valve) at the end of the suction pipe, this reduces the maintenance on this item and potential plugging.

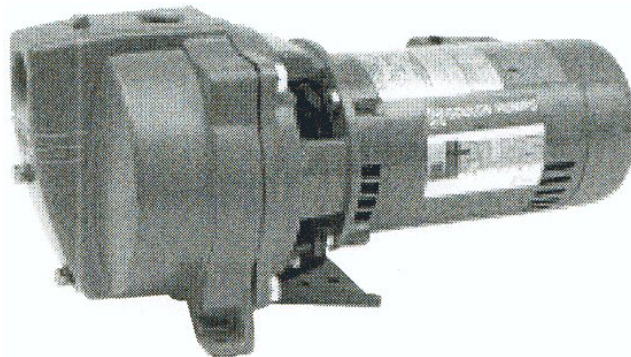

*Figure 1a A typical jet pump by Goulds, see <http://www.goulds.com/master.asp?id=3>*

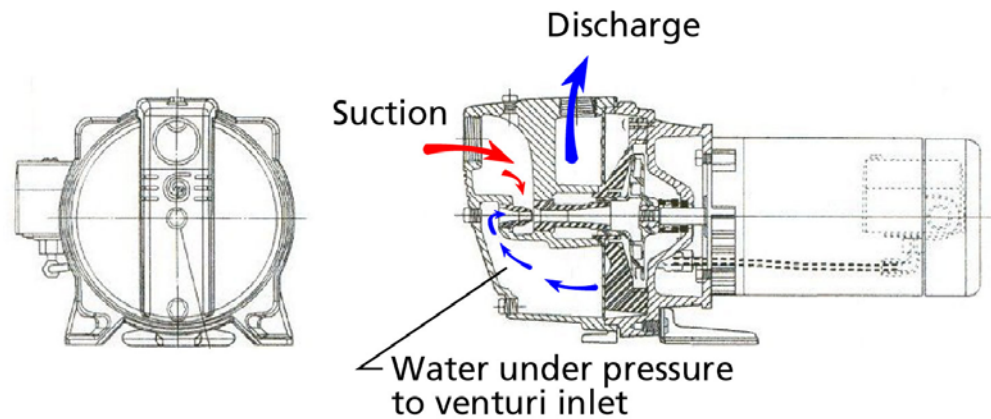

Figure 1b The venturi action of a jet pump.

### 1.1 VISCOUS DRAG PUMP

The impeller of this pump is a flat disc that accelerates the fluid by shearing the fluid. The ability of the fluid to resist this shear force (this is the definition of viscosity) means that a certain quantity of fluid will follow the disc and be accelerated towards the pump casing (see Figure 2). As in a normal pump, the velocity energy of the fluid is converted to pressure energy when the fluid hits the stationary casing. The advantage of this pump is that it can handle large quantities of air or gases and still perform which is not the case for traditional centrifugal pumps. Because the discs are open there are no tight passages as in traditional curved impeller vane passages and therefore solids can be handled effectively. These pump are available from the Discflo Corporation in a variety of sizes.

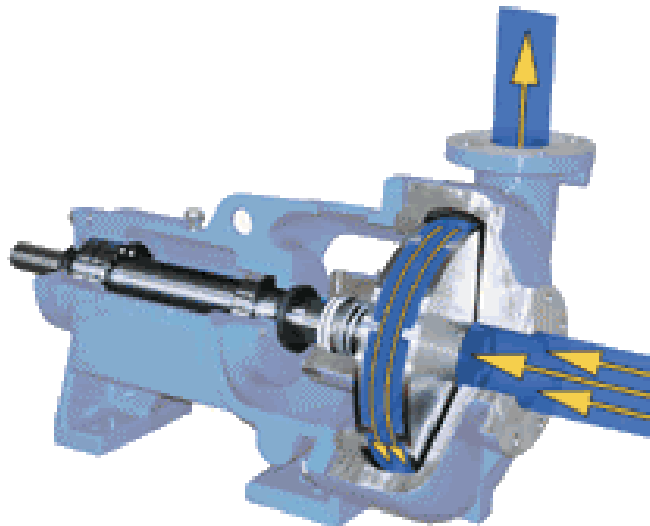
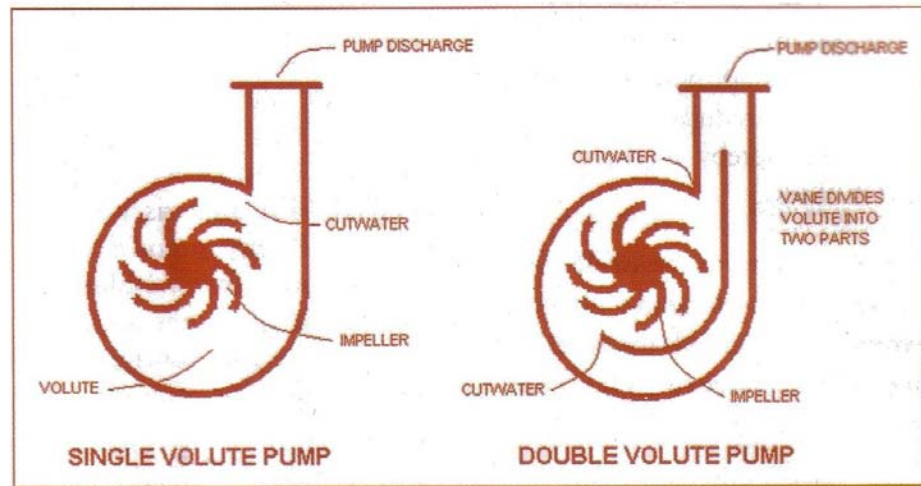

Figure 2 The discflo pump by Discflo Corp.  
see <http://www.discflo.com/>

## 1.2 DOUBLE VOLUTE PUMPS

A double volute pump is one where the immediate volute of the impeller is separated by a partition from the main body of the casing. The result is that the impeller is subjected to equal forces that are generated at the cutwater positions (see Figure 3a) and therefore is balanced hydraulically. A single volute pump always has a net hydraulic force that acts on the impeller causing wear and tear on the rotating components, the force gets larger the further one operates away from the optimum flow at the Best Efficiency Point (B.E.P.).



*Figure 3a Schematic of the double volute design (source: Pumps & Systems magazine June 2004)*

The double volute pump is therefore more robust and will require less maintenance, however it is less efficient and more expensive.

Double volute pumps are available in the medium to large size pumps from most manufacturers (see Figure 3b).

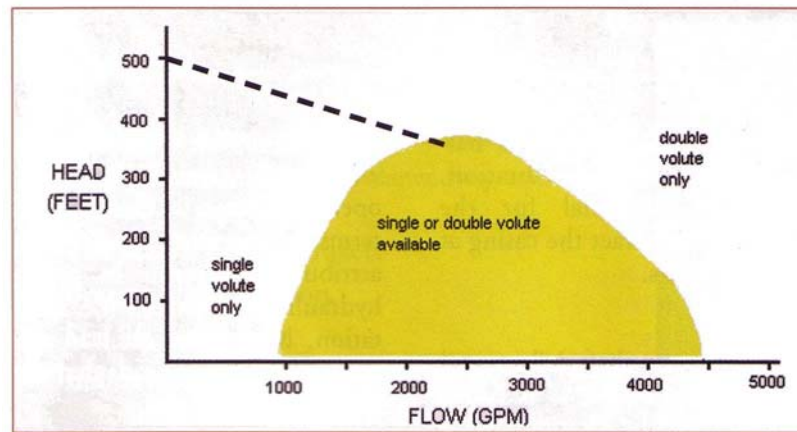

Figure 2. Double/single volute pump availability for between the bearings pumps

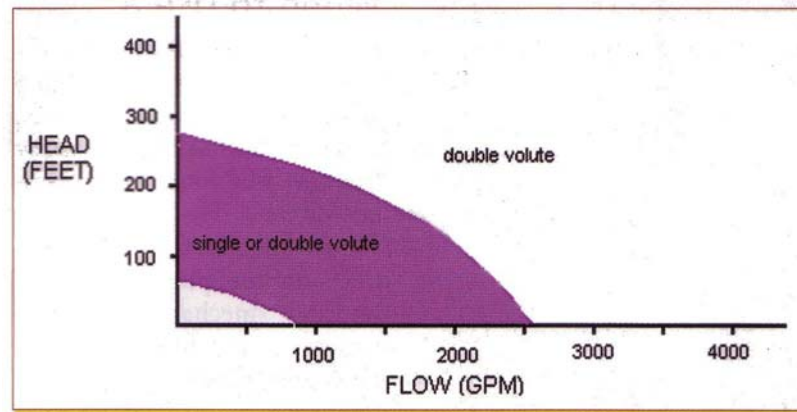

Figure 3b Availability of double volute pumps (source: Pumps & Systems magazine June 2004)

### 1.3 CHOPPER PUMPS

This type of pump has a serrated impeller edge which can cut large solids and therefore prevent clogging (see Figure 4). It is used for municipal waste handling and would no doubt be very useful for handling slurries containing many different type of solids such as in the pulp and paper industry.

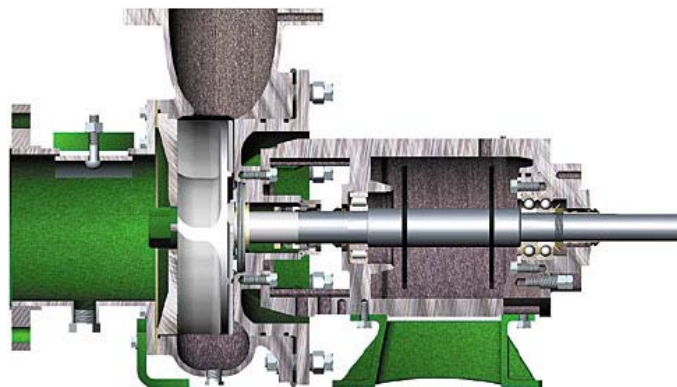

Figure 4 The Chopper pump by The Vaughan Co. Inc. see <http://www.chopperpumps.com/>

## 1.4 ROTATING CASING (PITOT) PUMPS

This pump's specialty is low to medium flow rates at high pressures. It is frequently used for high pressure shower supply on paper machines.



*Figure 5a The rotating casing Roto-Jet pump by Weir specialty Pump see <http://www.rotojet.com/>*

Roto-Jet pumps are designed with only two working parts, a stationary pick-up tube (pitot tube) and a rotating casing (see Figure 4b). These pump come with a built in recirculation line with an orifice which can bleed high pressure fluid from the discharge to the inlet to avoid damage due to running the pump with a closed discharge valve.

An alternate choice to this pump is a multi-stage centrifugal pump such as the Goulds model 3355 which can be seen at [http://www.gouldspumps.com/cat\\_pumps.ihtml?pid=602&lastcatid=86&step=4](http://www.gouldspumps.com/cat_pumps.ihtml?pid=602&lastcatid=86&step=4)

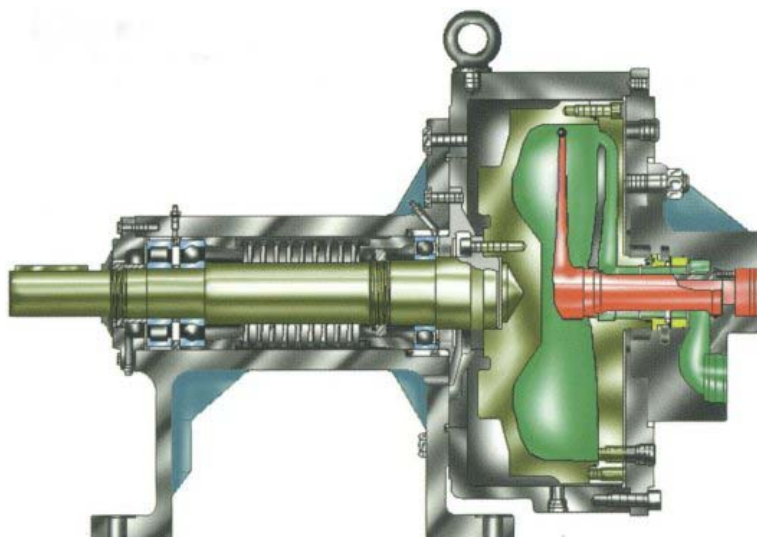

*Figure 5b A sectional view of the rotating casing Roto-Jet pump.*

## 1.5 RECESSED IMPELLER

This pump is a frame-mounted, back pull-out, end suction, recessed impeller, tangential discharge pump designed specifically to handle certain bulky or fibrous solids, air or gas entrained liquids or shear sensitive liquids (see Figure 6). For example, certain bulky or fibrous solids like some long denim fiber or recycle stock can clog or abrade parts of conventional process pumps. In addition, shear sensitive liquids like latex are degraded when pumped at high velocities through process pump casings. Last, if air or gas binding is a problem, the recessed impeller is the answer, it can also handle liquids with up to 5% entrained air or gas.

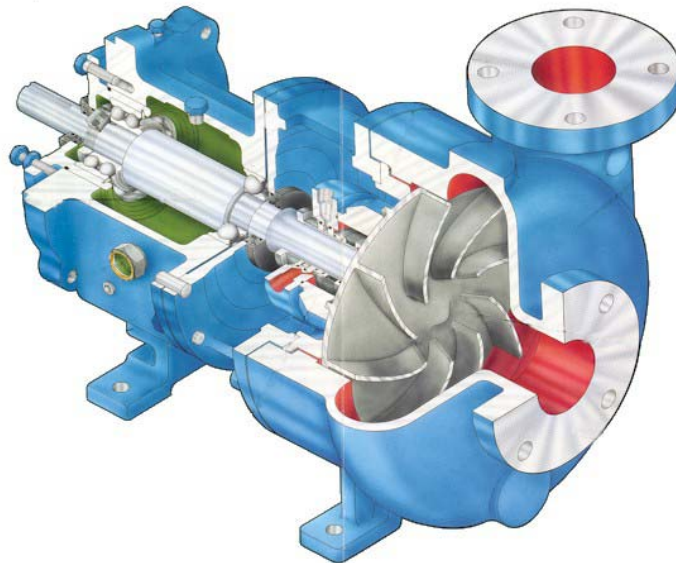

*Figure 6 A sectional view of a recessed impeller pump by  
Goulds see <http://www.mackpump.com/CV3196.htm>*



## 1.6 SELF-PRIMING PUMPS

Reliable Self-Priming Operation - Before any centrifugal pump will perform, it must first be primed; that is, air or gases expelled from the suction and impeller eye area, and replaced with liquid.

This is no problem when the pump is submerged (submersible or vertical sump pumps) or when liquid supply is above the pump. However, when suction pressure is negative, air must be evacuated to accomplish pump priming.

The self-priming pump is designed to insure that a sufficient quantity of liquid to reprime is always retained in the priming chamber (see Figure 7b).

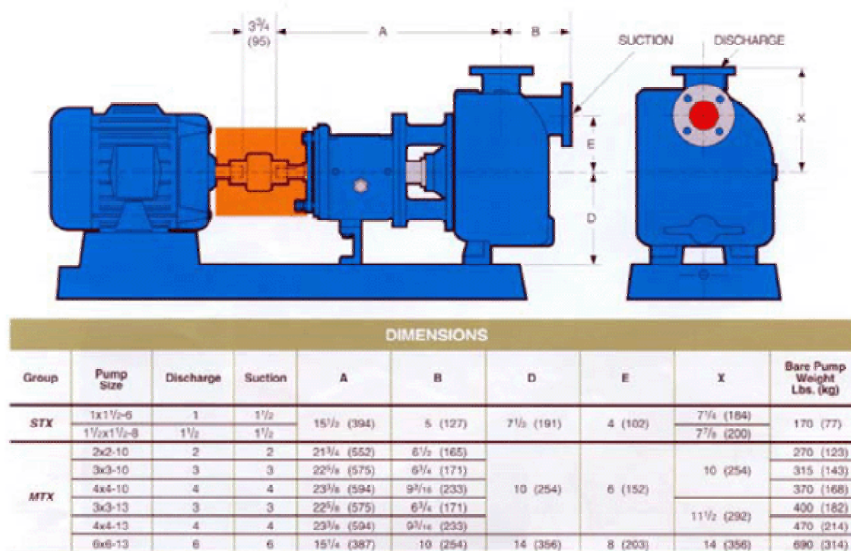
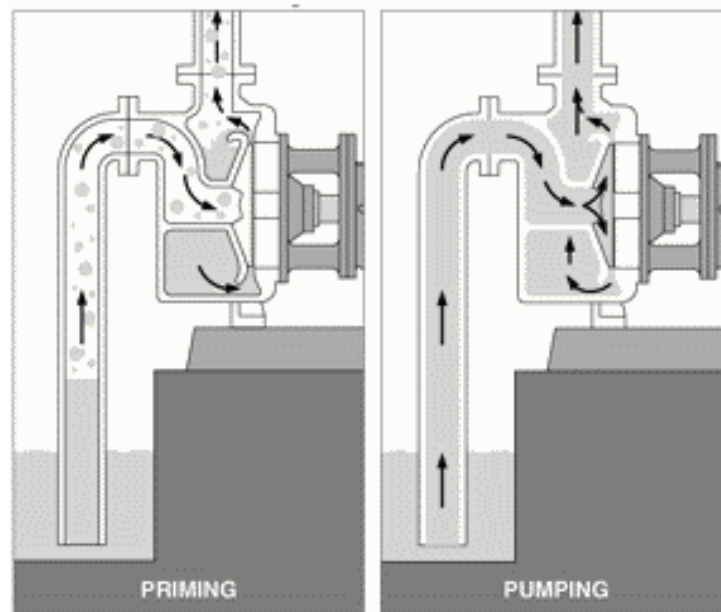

Figure 7a Outside dimensions for a self-priming pump by Goulds see [http://www.gouldspumps.com/cat\\_pumps.ihtml?pid=226&lastcatid=76&step=4](http://www.gouldspumps.com/cat_pumps.ihtml?pid=226&lastcatid=76&step=4)



*Figure 7b Priming and pumping action of a self-priming pump.*

## 1.7 SLURRY PUMPS

The slurry pump is a rugged heavy duty pump intended for aggressive or abrasive slurry solutions with particles of various sizes. It achieves this by lining the inside of the pump casing as well as the impeller with rubber (see Figure 8). All though rubber does eventually wear, the elasticity of its surface allows the hard mineral particles to bounce off thereby reducing what would be otherwise very aggressive erosion. These pumps are used wherever abrasive slurries need to be pumped, especially in the mining industry. The NPSH requirement for these types of pumps is typically higher than comparative standard centrifugal pumps.



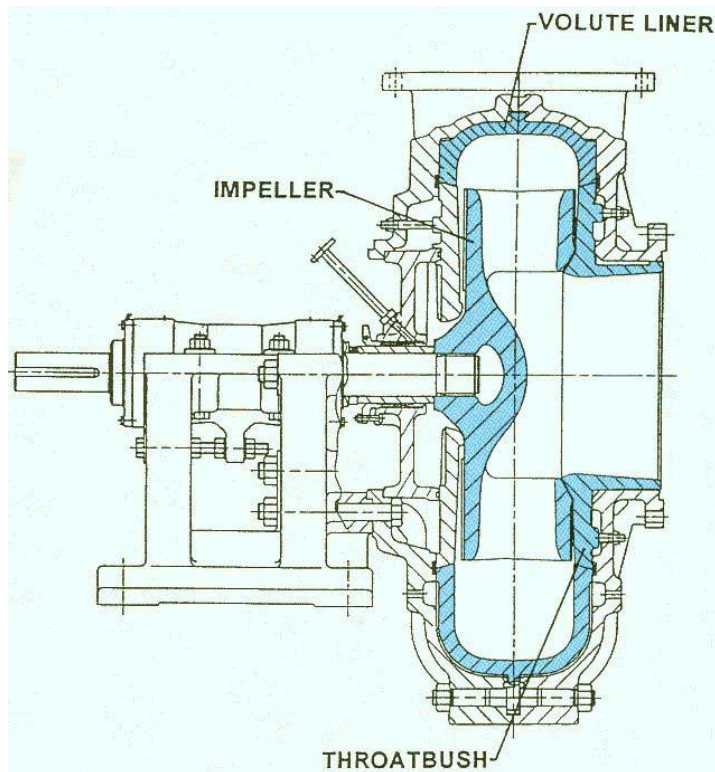

Figure 8 Slurry pump by Warman see <http://www.warman.co.za/>

### 1.9 LOW FLOW HIGH HEAD PUMPS (RADIAL VANE OR PARTIAL EMISSION)

This radial vane or partial emission pump (see Figure 10) is a frame mounted, end suction, top centerline discharge, ANSI pump designed specifically to handle corrosive chemicals at low flows.

By low flows we mean:

- Flows outside the recommended operating range of typical end suction pumps.
- Low flows which require users to throttle end suction pumps to operating conditions well below their best efficiency point.
- Flows that increase mechanical vibration, decrease bearing and seal life, increase maintenance costs, and decrease the pump life of end suction pumps.

In other words, the radial vane pump is designed to operate where standard end suction pumps operate poorly - at throttled low flows.

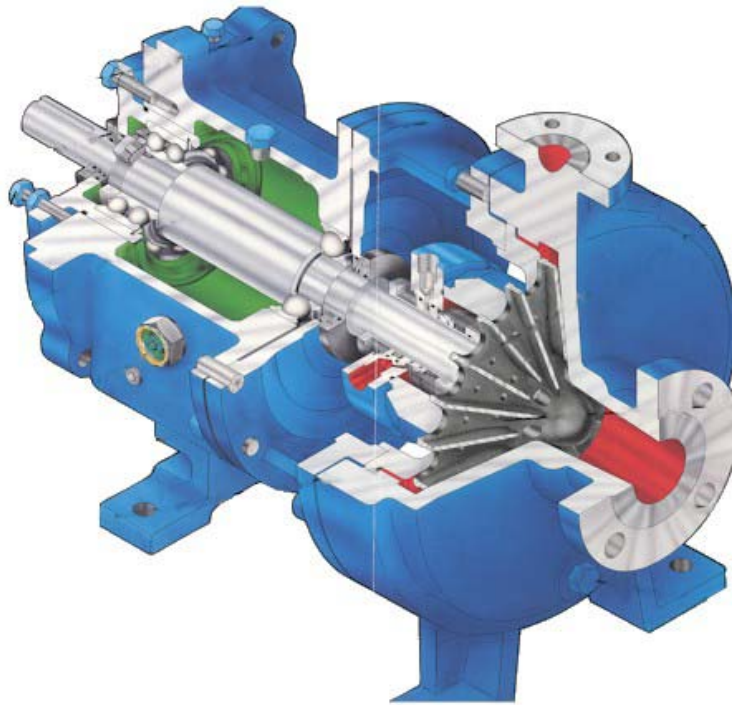

*Figure 10 Low flow vane pump by Goulds see <http://www.mackpump.com/LF3196.htm>*

#### 1.9 LOW N.P.S.H. PUMPS (LOW FLOW, HIGH HEAD)

This type of pump is used where the available N.P.S.H. is low (see Figure 10). It is specifically designed for low flow and high head requirements and offers good efficiency even under these conditions (see the article published by Industrial Technology magazine at <http://www.industrialtechnology.co.uk/1998/may/impeller.html>).

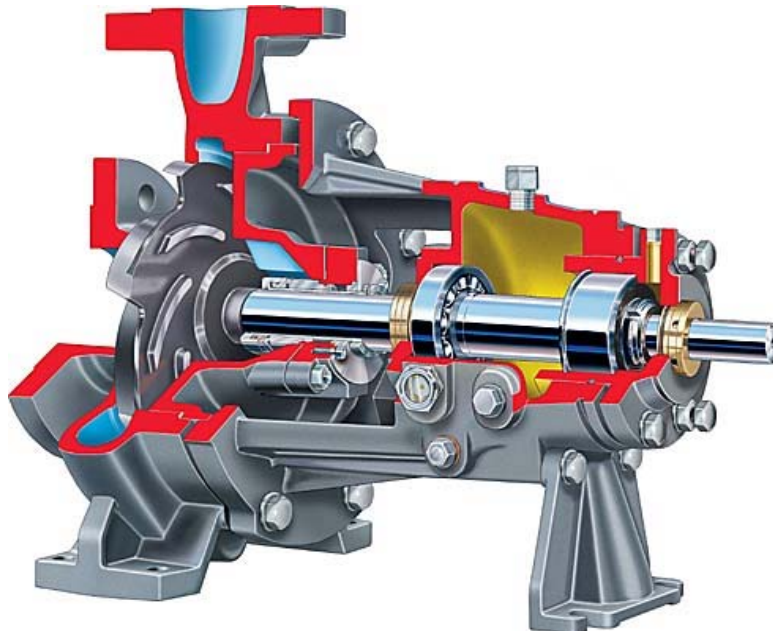

*Figure 10 Low N.P.S.H. pump (model CPX) by Flowserve see [http://www.fpdlit.com/cms/results\\_detail.asp?ModelID=10](http://www.fpdlit.com/cms/results_detail.asp?ModelID=10)*

## 1.10 SLUDGE PUMP

Certain types of sludges tend to settle very quickly and are hard to keep in suspension. The Lawrence pump company has solved this problem by putting an agitator in front of the pump suction (see Figure 11). For more info see the Pumps & systems magazine, issue March 2004 at <http://www.pump-zone.com/>.

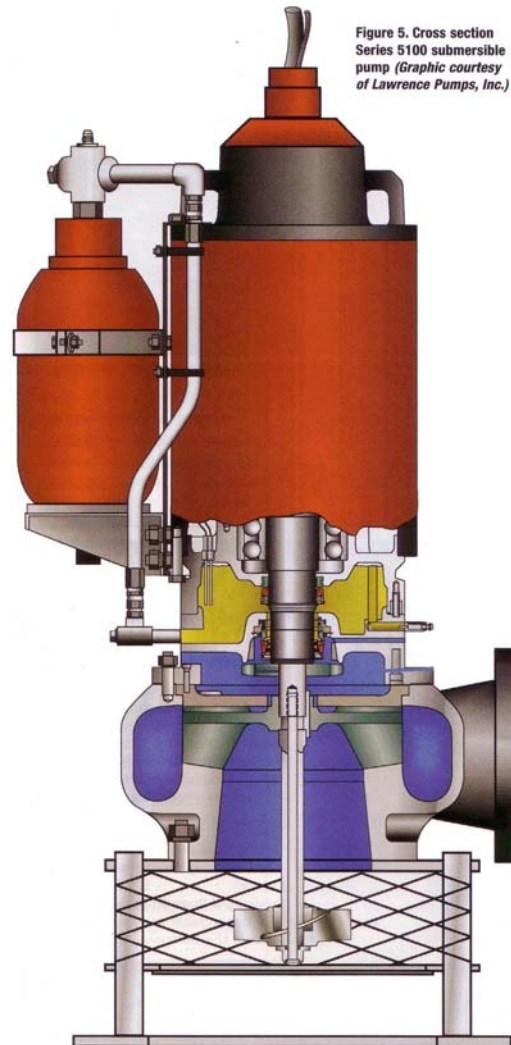

Figure 5. Cross section  
Series 5100 submersible  
pump (Graphic courtesy  
of Lawrence Pumps, Inc.)

Figure 11 Lawrence Series 5100  
submersible pump with sludge agitator,  
<http://www.lawrencepumps.com/>